

FMS Belt Scales / Measuring Rollers

BMGZ041-Series Robust measuring rollers for troughed conveyor belts

- **Longest lifetime**
Robust design, all components enclosed, integrated, contact-less speed detection
- **Precise measuring results**
10'000-times proven technology, direct force detection on the shaft, w/o deflection or any braces
- **Compact, maintenance-free**
Integrated speed detection without friction wheel, dual shaft sealings
- **Simple and universal retrofit**
Sophisticated and proven concept with multiple installation options

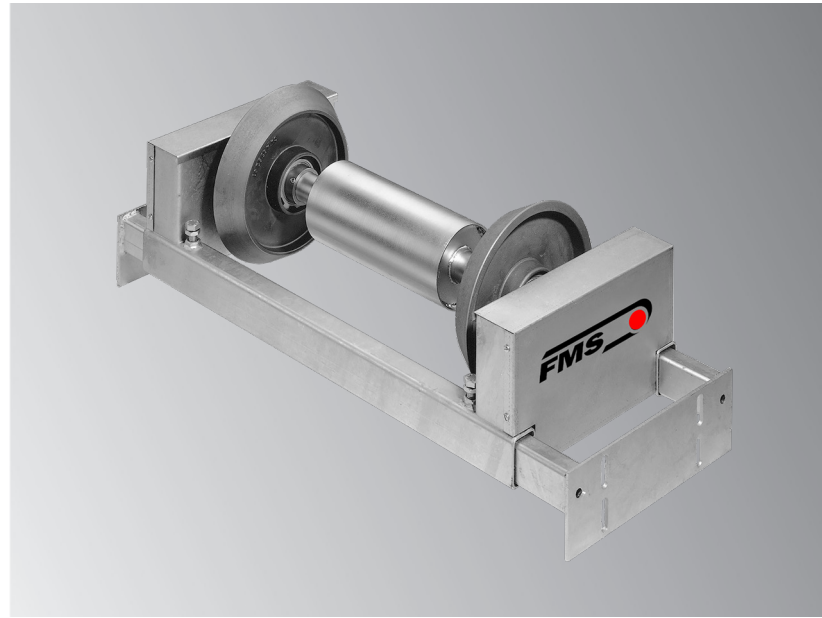

BMGZ041-Series

The toughed measuring rollers of the BMGZ041-series are designed for operation in most severe conditions and under steady load in mobile and stationary plants that process heavy, bulky goods, such as sand, gravel, stones, coal, building rubble etc. A wide portfolio of sizes and troughing angles for standard belts offers solutions for most applications. The beveled side disks are slidable and allow for easy adjustment to non-standard belt types and dimensions.

Functional description

The FMS measuring roller normally substitutes a regular idler roller station of the conveyor belt. The FMS measuring roller is selected according to the width and troughing angle of the conveyor belt. The center roller and the two beveled side disks are mechanically separated and allow for easy adjustment of the belt cross section according to your specific belt type or dimensions. Both measuring roller axis are supported by force measuring sensors. This direct measurement at the point of load transmission makes the measuring system insensitive to forces that act in direction of the moving belt. Additional components (guiding beams and connections to the frame, etc.) to isolate the force are not required and lead to an extremely slim design. With an installation height of only 180 mm (7.1 in.) or 240 mm (9.5 in.) the FMS measuring roller can be easily installed where space is limited, e.g. in mobile crushers or screening plants. The adjustable support of the measuring roller can be adapted to various frame dimensions and widths.

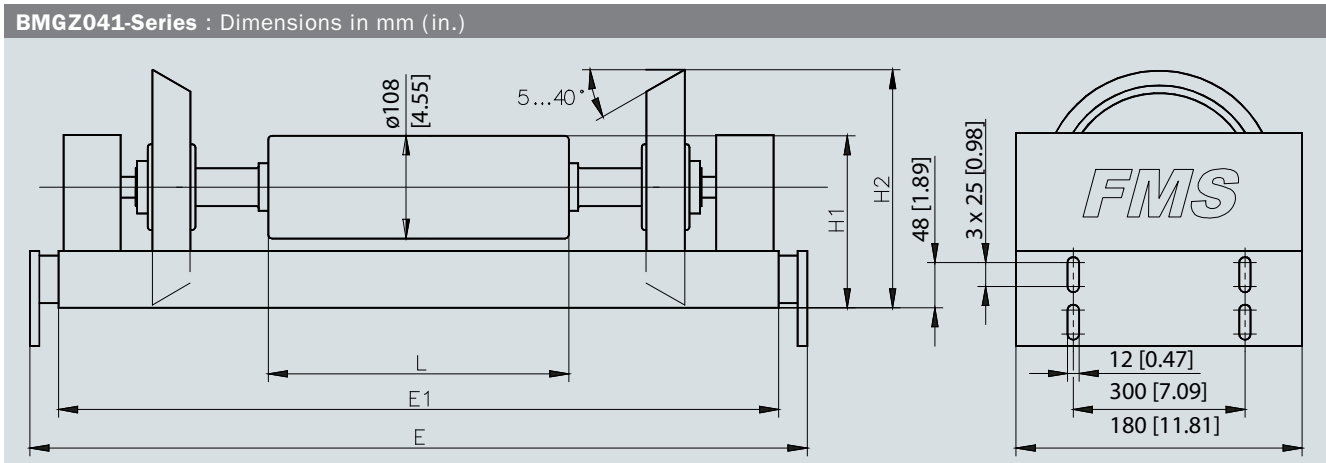

BMGZ041-Series : Dimensions

Type	Belt width mm (in.)	L mm (in.)	E mm (in.)	E1 mm (in.)	H1 mm (in.)	H2 mm (in.)
BMGZ041.02	500 (19.7)	200 (7.9)	620 – 990 (24.4 – 39.0)	600 (23.6)	180 (7.0)	232 (9.1)
BMGZ041.03	650 (25.6)	250 (9.8)	720 – 1090 (28.3 – 42.9)	700 (27.6)	180 (7.0)	250 (9.8)
BMGZ041.04	800 (31.5)	315 (12.4)	830 – 1200 (32.7 – 47.2)	810 (31.9)	180 (7.0)	250 (9.8)
BMGZ041.05	1000 (39.4)	380 (15.0)	1045 – 1415 (41.1 – 55.7)	1025 (40.4)	240 (9.4)	352 (13.9)
BMGZ041.06	1200 (47.2)	465 (18.3)	1180 – 1550 (46.5 – 61.0)	1160 (45.7)	240 (9.4)	352 (13.9)
BMGZ041.07	1400 (55.1)	530 (20.8)	1395 – 1765 (54.9 – 69.5)	1375 (54.1)	240 (9.4)	352 (13.9)

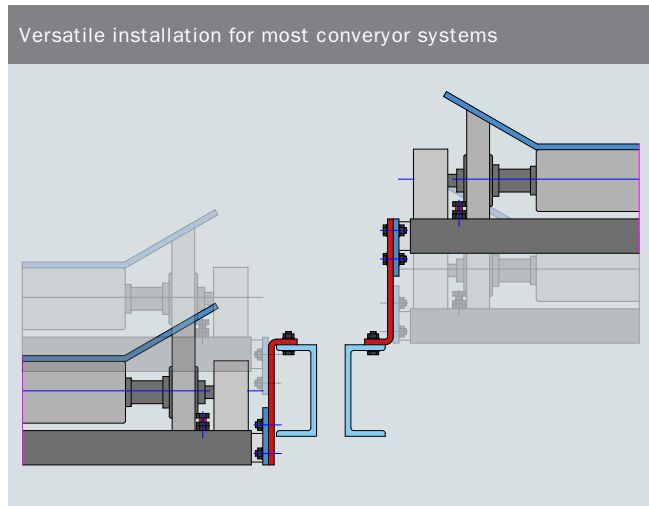
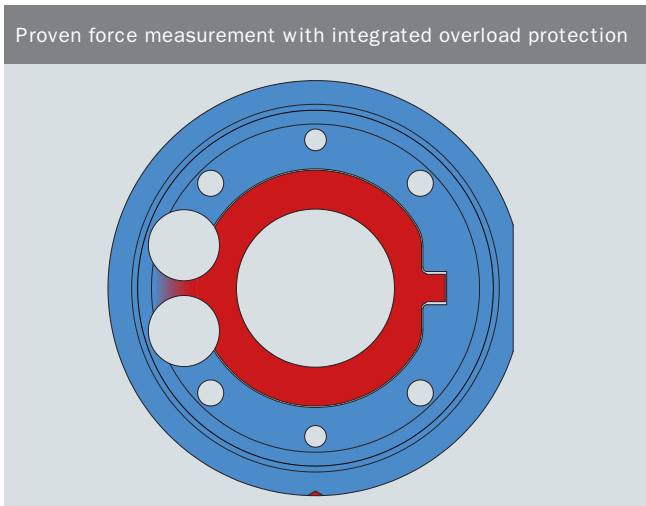
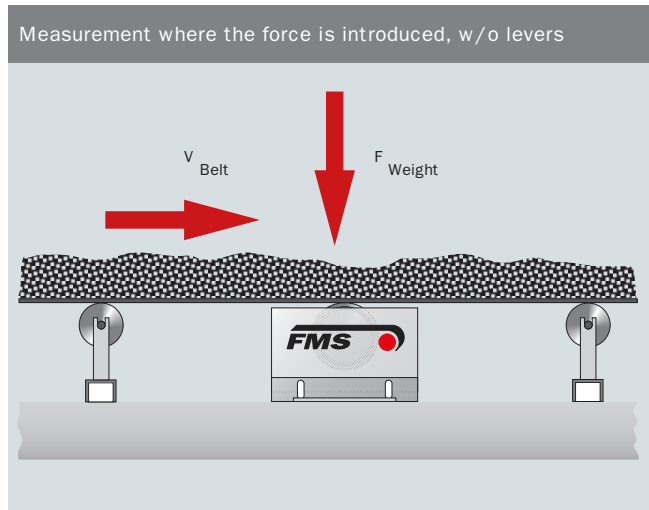
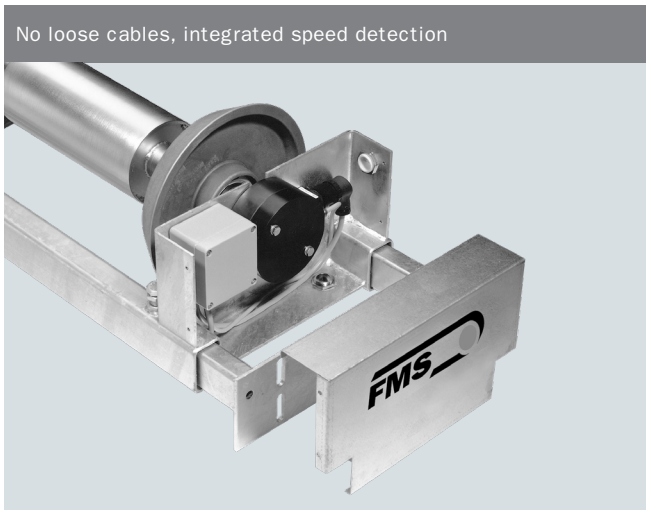

BMGZ041 : Technical data

Accuracy class	± 0.3 % (F _{Nenn})
Temperature range	-10 to +60 °C (14 to 140 F)
Overload protection force sensor	10 times nominal force (F _{Nom})
Material frame	galvanized steel
Protection class	IP67

BMGZ041 : Order code

BMGZ041.05224	
	Increment of speed detection
	Nominal force of the force sensor (encoded)
	Troughing angle (0° to 45°)
	Belt width (encoded)
	Series

BMGZ041 : Scope of supply

● measuring roller ● electronics (separate order) ● installation bracket ● no additional installation material

BMGZ041 : Accessories

● connection cable from measuring roller to electronics, 15 m (49 ft.) (other lengths on request)

BMGZ041 : Typical application



Other products : Construction and Recycling

BMGZ710 electronics



BMGZ021 measuring roller for flat belts



About us

FMS Force Measuring Systems AG is the market leader in the field of web tension measurement, control and specialist for web guiding solutions. For the wire industry we are the only manufacturer offering a complete range of technologies for force measurement, data processing and radio transmission of signals.

Our in house developed products are used in the manufacturing industry, converting, metals, paper, textiles, as well as in cable and wire rope production. Utilising the latest technology, high quality components and a firm understanding of customer applications, FMS supports customers worldwide in the effort to maximize the productivity of their machines. Since 1993, our highly qualified employees have been creating high-end solutions for machine builders and plant operators. As an owner-managed company, we pride ourselves on being personal and approachable with the ability to make decisive moves fast.

World Headquarters: FMS Force Measuring Systems AG

Aspstrasse 6 • 8154 Oberglatt (Switzerland) • Phone + 41 44 852 80 80 • Fax + 41 44 850 60 06
info@fms-technology.com • www.fms-technology.com